

UNIMAC CHECK VALVES

Wafer Check valves

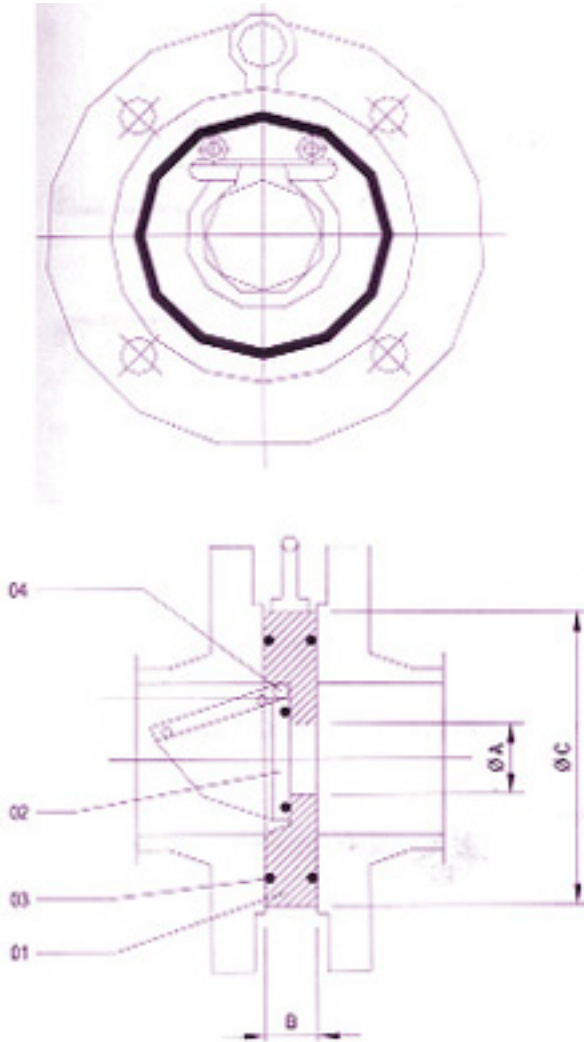

Technical Data	
Manufacturing STD	: API 6D/ ANSI B16.34
Testing & Inspection STD	: API 598
Pressure class	: DN ND 10, ND 16 & ND 40, ASA 150, 300

No.	Description	Material	Qty.
01	Body	C.I. IS : 210 GR. FG 200/ ASTM A 216 GR WCB	1
02	Disc	AISI 304 /G.M.	2
03	Hinge Pin	AISI 304 /AISI 316	1
04	Plug	AISI 304 /AISI 316	2
05	Stop Pin	AISI 304 /AISI 316	1
06	Spring	AISI 304 /AISI 316	2
07	Bearing	AISI 304 /AISI 316	1

Size	50	65	80	100	125	150	200	250	300
ø A	30	40	52	71	93	114	157	195	230
B	14	14	14	14	16	19	28	28	28
øC	109	129	144	164	194	220	275	330	380

All dimension are in mm

Suitable for Water and Oil

Primary service Rating & Test Pressure			
Class	Working Temp.	Hyd. Test Pressure	
		Body	Seat
150	20° C to 180°C	225 PSIG	150 PSIG

Note : Due to constant up gradation, dimensions are subject to change by the manufacturer.